

RoHS

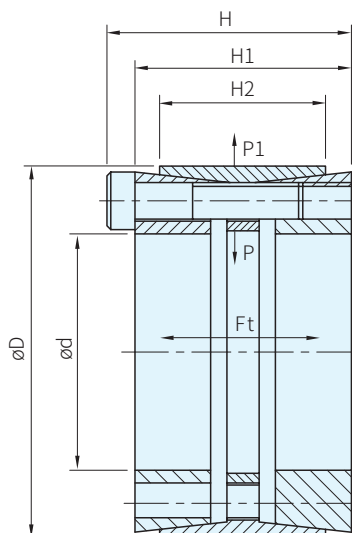

材質

S45C

品號	庫存	d	D	H	H1	H2	軸向推力 Ft(KN)	傳達扭矩 Mt(Nm)	軸面壓力 P(N/mm ²)	截面壓力 P1(N/mm ²)	12.9級螺絲		鎖緊扭矩 Ts(Nm)			
											數量	規格				
SF-25	△	25	55	51	45	32	64	799	314	107	6	M6×35	17			
SF-28	△	28	55					32	64					895	281	
SF-30	△	30	55											32	64	959
SF-35	△	35	60			44	135	75	1306	185	83	7				M8×50
SF-38	△	38	65					44	135	2567	308			121	7	
SF-40	△	40	65							44	135	2702				293
SF-42	△	42	75					44	135			2837		279	108	9
SF-45	△	45	75							44	135	3040		260		
SF-48	△	48	80					72	64			56		3707	216	121
SF-50	△	50	80							72	64			56	3861	
SF-55	△	55	85	88	78	70	174	4779	212			108	10		M12×80	
SF-60	△	60	90				70	193	5793	216	113	11		M12×80		
SF-65	△	65	95						70	193	6276					199
SF-70	△	70	110				70	313			10951	235		120		13
SF-75	△	75	115						70	313	11733	220		115		
SF-80	△	80	120				70	344			13768	227		121		15
SF-85	△	85	125						70	344	15959	233		127		
SF-90	△	90	130				70	376			16898	220		122		17
SF-95	△	95	135						70	376	17837	208		117		
SF-100	△	100	145				130	116			104	501		25029		211
SF-110	△	110	155	104	546	30039			209	115		15	M16×120			
SF-120	△	120	165			104			637	38226				224	127	16
SF-130	△	130	180	104	743					48270		201	117	17	M16×120	
SF-140	△	140	190			104			866	60654		217	129			18
SF-150	△	150	200	104	928					69628			206	132	19	
SF-160	△	160	210			104			990	79220		208		134		20
SF-170	△	170	225	134	1186					100851			210	116	21	
SF-180	△	180	235			134			1271	114414		210		119		22
SF-190	△	190	250	134	1356					128814			200	115	23	
SF-200	△	200	260			134	1356	135594	200	115	24	M16×120				

Ps. 備註

・自動校對

訂貨：品號 交期：14 天

SF-25